

RotoMAXX™ II



High Torque, Right Angle Slow Speed Agitator

Advanced Mixing Technologies

NEW!
Brute Force
& Durability

Premium 316SS machined for greater corrosion resistance.

Dual, single-lip seals provide ultimate cleanliness

Impeller shaft length available up to 365 cm



Jetfoil™ impeller technology provides 200% greater pumping rate over conventional axial blade impellers.

▲ Motors are 300 Series Stainless Steel

The only all stainless steel, low speed, large capacity agitator

The robust **RotoMAXX II**, with right angle helical bevel gearbox, is designed for the most demanding operating environments and stringent CIP, washdown, pressure washing, and steam cleaning conditions.

The modular design allows for multiple shaft diameter, gear ratio, and motor horse power combinations with flex couplings between the motor/gearbox and gearbox/drive shaft to protect the gear drive from shock loads and dampen vibrations while isolating shaft bending moment and deflection loads from the torque loads on the gearbox.

The Admix Advantage

- ✓ Tank volumes to 225.000 liters
- ✓ Entire unit is designed for total wash-down duty for food, pharmaceutical and cosmetic industries
- ✓ Maintenance-free, greased-for-life, sealed bearings in bearing frame
- ✓ Premium high efficiency, ground helical bevel gearing provides 20-30% more efficient gearing than conventional worm gearing
- ✓ Synthetic food grade lubrication in gear drives
- ✓ Up to 11kW Input
- ✓ Output torque up to 690 Newton meter with 1,25 service factor

RotoMAXX™ II Specifications

The RotoMAXX II series of stainless steel mixers are available in three (3) basic configurations as shown below:

Mixer Model	420RMAX	620RMAX	625RMAX
Output Speed (RPM)	13 - 311	12 - 240	12 - 240
kW Range	0,75kW - 5,5kW	0,75kW - 7,5kW	0,75kW - 11kW
Shaft Diameter	50,8 mm	50,8 mm	63,5 mm
Maximum Shaft Length	Up to 330 cm	Up to 330 cm	Up to 365 cm
Impeller Diameter	Up to 127 cm	Up to 165 cm	Up to 203 cm
Pumping Rate @ 1 cPs (LPM)	Up to 90.000 liters	Up to 150.000 liters	Up to 210.000 liters

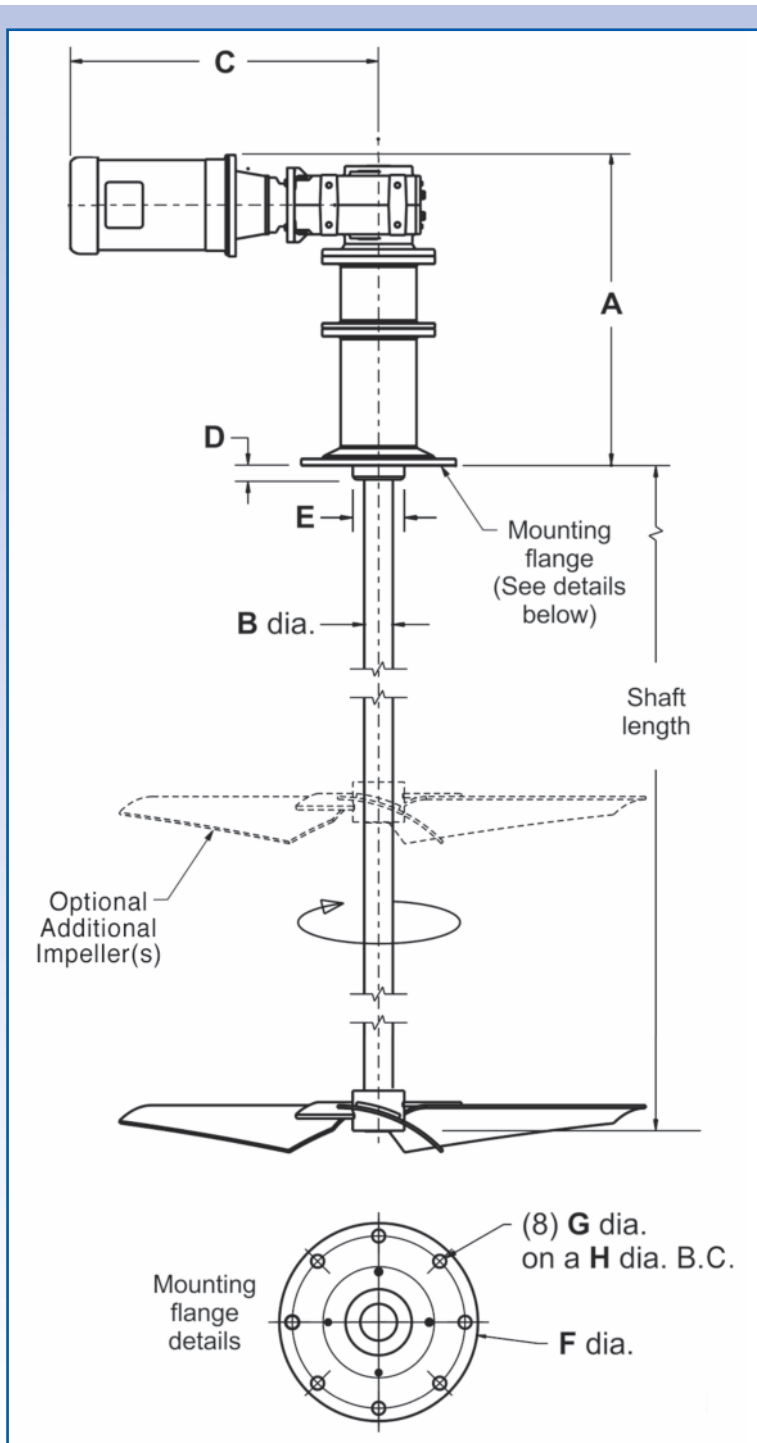

Features & Benefits

- ✓ Mounting for NEMA or IEC C-face/B5 Motors
- ✓ Flex couplings between the motor/gearbox and gearbox/drive shaft provide vibration damping and shock load protection to drive components.
- ✓ Three waterproof pressure compensation vents allow air inside the gearbox and driveshaft bearing frame to expand and contract as temperatures inside and outside the agitator change and prevent moisture and contaminants from getting in.
- ✓ All non-rotating components are sealed with o-rings for greater protection
- ✓ Impeller shaft speeds from 12 to 311 rpm
- ✓ 50,8 mm to 63,5 mm diameter impeller shaft
- ✓ Impeller shaft available up to 365 cm
- ✓ 3-A compliant seal pedestals are available
- ✓ Permanent laser-marked nameplate

RotoMAXX™ II Dimensions

	420RMAX	620RMAX	625RMAX
A	645,16	693,42	693,42
B	50,8	50,8	63,5
C	736,6	838,2	838,2
D	31,24	31,24	31,24
E	170,18	190,5	190,5
	152,4-150# ANSI	203,2-150# ANSI	203,2-150# ANSI
F	279,4	342,9	342,9
G	22,35	22,35	22,35
H	241,3	298,45	298,45

Dimensions are in mm
C & A may vary depending on motor kW

For more information:

**EMPLOYEE OWNED...
CUSTOMER FOCUSED**