

Technology designed for 24/7 operation

The Dynashear represents the latest technology for sanitary inline continuous processing, or batch processing with recirculation. The Dynashear will mix, dissolve, deagglomerate, disperse, and emulsify a wide range of fluids and semifluids, and is particularly effective for wetting out powders into a liquid. It features a first-in-class tandem head design combining the benefits of both an axial and a radial stage, creating excellent shear and flow characteristics. The result is droplet size reduction as low as 2 - 3 microns and a very narrow distribution, plus flow capacities that are substantially higher than existing inline mixers.



**DS-425 / DS-575
production size models**



VFD interface

**LAB SCALE
SIZE NOW
AVAILABLE!**

**DS-215
lab scale model**

The DS-215 is designed for product development, simulation, and scale up. Predictable, repeatable results from lab to full production!

The Dynashear advantages – making your job easier and faster!

- CIP capability
- Total washdown and for selected models conforming to the EHEDG TYPE EL Class 1, hygienic design guidelines, available on request
- Low maintenance design for minimum downtime – no bushings, wear sleeves, shims or bearing supports to wear out
- Disassemble and reassemble for inspection and cleaning in less than five minutes
- Processes from 1 - 662 liters per minute, model dependent
- Seal pressure ratings up to 31 bar at 204° C, model dependent
- Selection of single and double-barrier mechanical seals designed for sanitary applications with CIP requirements. Lab model offered with single seal only.
- VFD recommended on all models for speed adjustment



Dynashear Inline Mixing Technology Improves Your Process

The Dynashear is designed to provide maximum versatility to meet your processing needs, and is offered in several different configurations. Whether you are looking for a stand alone inline mixer, a mixer to enhance performance of your batch process agitator, or further product refinement, the Dynashear ensures consistent quality with precise reproducibility.

Dynashear Sizing and Engineering Data

Model	Axial Diameter (mm)	Axial Tip Speed (m/s)	Radial Diameter (mm)	Radial Tip Speed (m/s)	Motor Size (kW)	Motor Speed (rpm)	Typical Flow Rate Ranges (l/min)
DS-215	31.75	11.5	54.1	19.5	1,5	6,900	8 - 83
DS-425	57.15	10.6	107.9	20.4	4	3,600	76 - 303
DS-575	92.96	17.6	146.05	27.4	15	3,600	76 - 606

Note: Flow rates based on 1 centipoise. High viscosity liquids, high solids concentrations, or discharge head conditions may require a booster pump.

Dynashear Dimensional Data

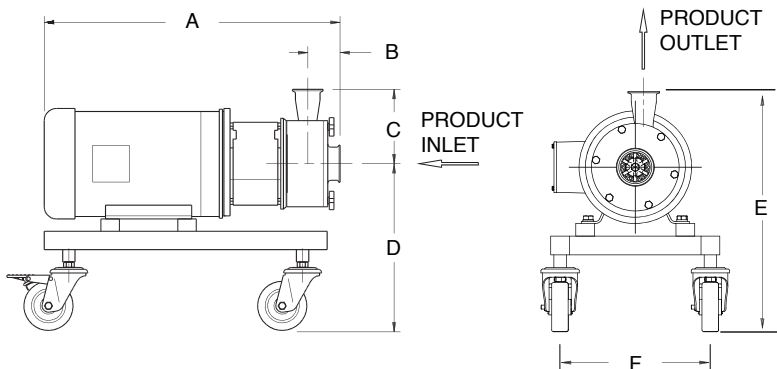

Model	Dimensions (mm)						Tri-Clamp® Fitting	
	A	B	C	D	E	F	Inlet	Outlet
DS-215	422	46	104	348	452	305	1.5"	1"
DS-425	635	66	155	333	488	305	2.5"	2"
DS-575	787	79	236	379	615	406	4"	3"

Note: Dimensions are approximate and subject to change.

DS-215 comes standard on a mobile cart. Overall dimensions = 711 mm length, 457 mm width, 991 mm height.

Advanced Dual Stage Design

The Primary Axial Stage

The axial stage consists of an axial flow rotor feeding into a stator with multiple small ports, forcing material between their faces and out through the ports. This mechanical and hydraulic action causes tremendous shearing action and "pre-mixes" the materials prior to entering the secondary stage. Particle and droplet size reduction down to 5 - 7 microns is typical in this stage.



The Secondary Radial Stage



The radial stage consists of a radial, high flow rotor discharging through a slotted stator providing additional mechanical and hydraulic shear. The centrifugal force at this stage allows the mixture to be pushed away from the shaft and along the radius of the stator, forcing high speed expulsion at the edge of the slots.

This stage provides a substantial momentum change in the flow, resulting in beneficial residence time for further refining of the mixture. Stable emulsions with droplet sizes of 2 - 3 microns or less are typical within this stage.

The Benefits of Advanced Mechanical Design

This combination provides greater efficiency and effectiveness over conventional inline mixers that offer either all axial or all radial technology only. A single pass through the Dynashear matches product quality typical of multiple passes using conventional mixers.

